

Piping connected to the pump discharge -The pump is not shown here.

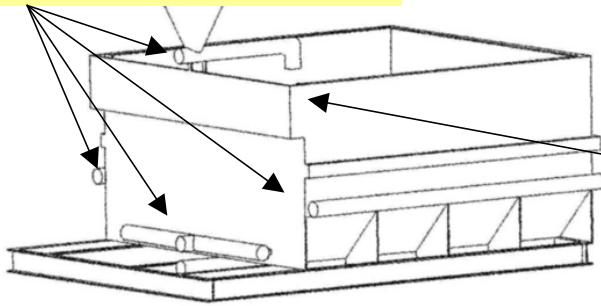

- 42" tank height.
- 6' 3" wide x 9' long
- Gas or Diesel option

Overflow trough to divert unmixed material on the surface to the mixing pump suction.

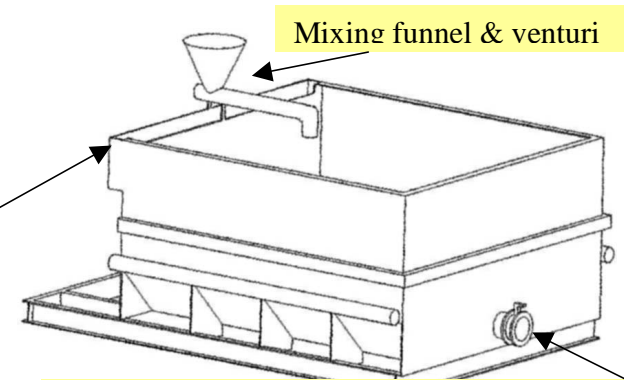

Mixing funnel & venturi

This tank drain allows the tank to be emptied quickly

Specifications,

- 1000 gallon capacity
- 3" pump, 400 GPM capacity, to allow for rapid mixing of the lubricant materials.
- 9 GPM piston pump delivers the mixed lubricant to the tunnel with a pressure of 850 psi.
- Venturi tube with a funnel mixes the material as the water is added.

Suction outlet

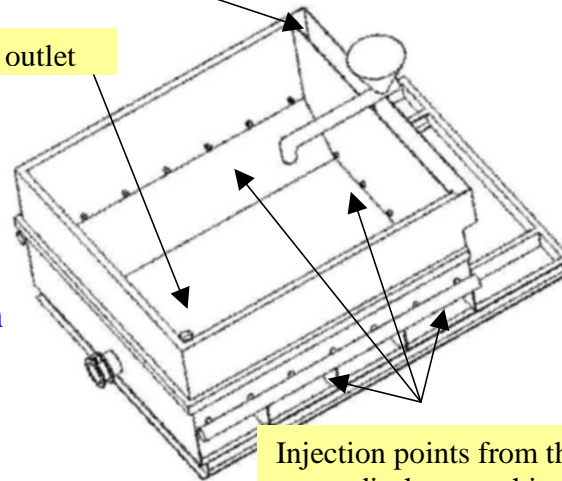

Injection points from the pump discharge – this creates turbulence in the tank.

- Pump flow is directed into the tank to create turbulence for better mixing.
- Overflow trough, to skim the surface material that hasn't mixed into the pump suction circuit.
- Compact design allows for easy mounting and transport on your truck or trailer.



L220

Tenbusch™ Equipment is designed and engineered with your production and profit in mind.



L175